

# Shrini's Crew

Camera platform stability for use in  
UAV remote sensing

Kellen Crawford

Matt Klein

Kevin Brouwers

# UAV



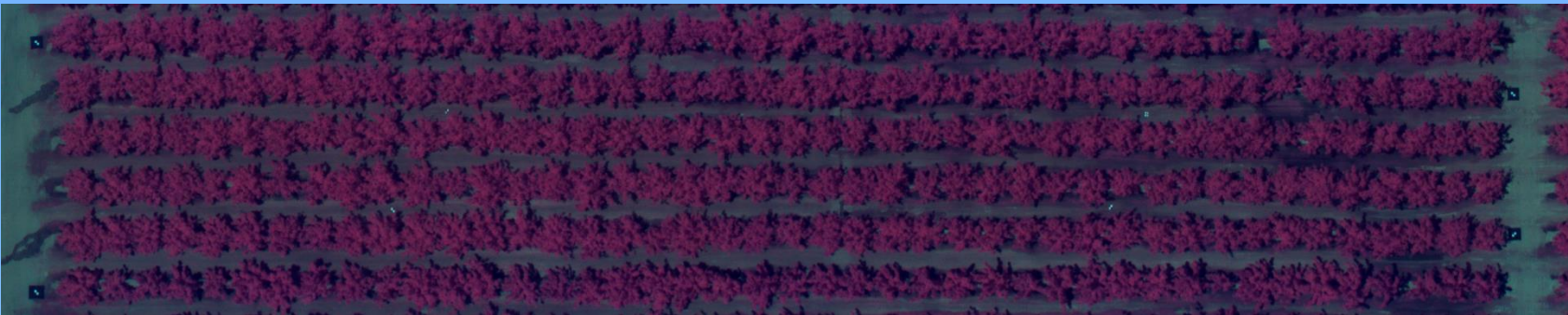

# Camera Platform

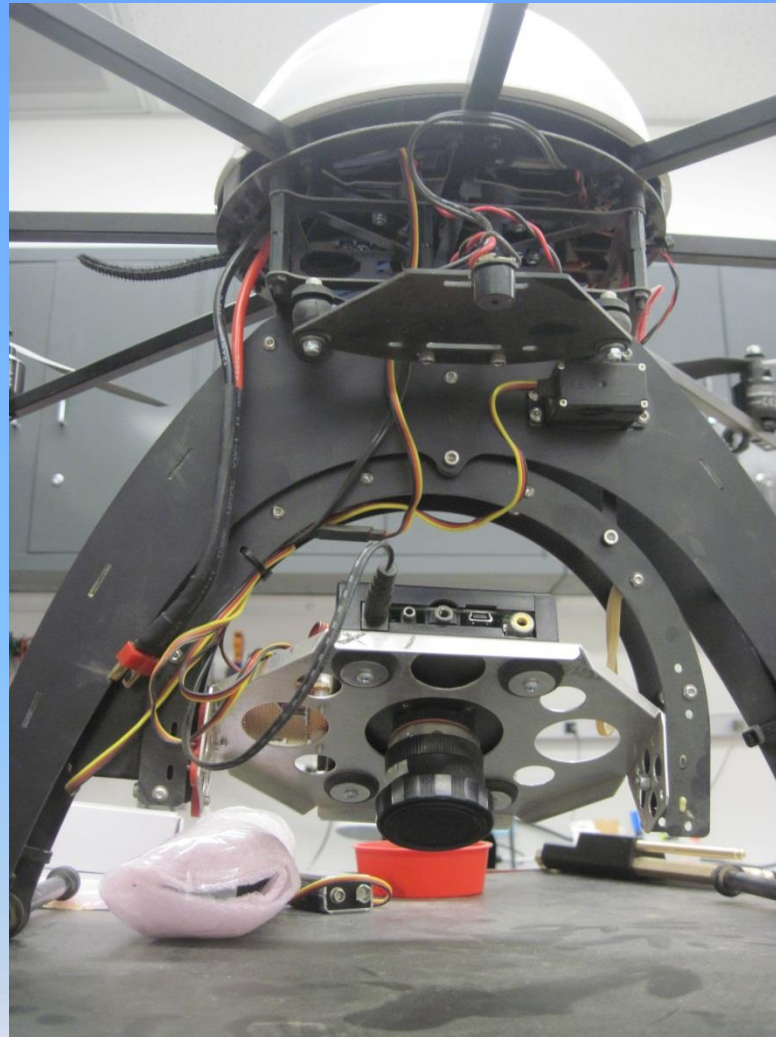



# ArduIMU - V3



# System Modeling

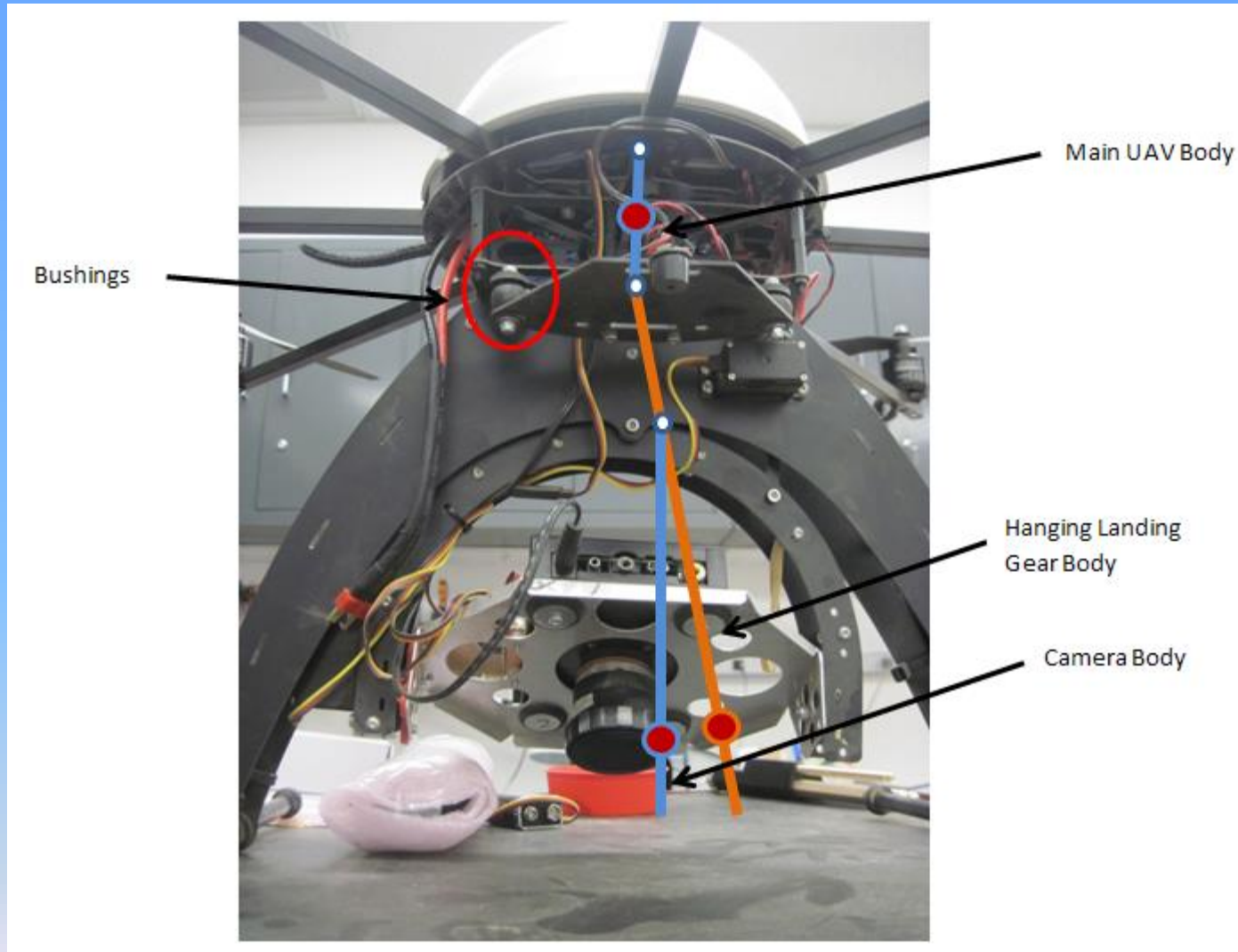

# System Modeling

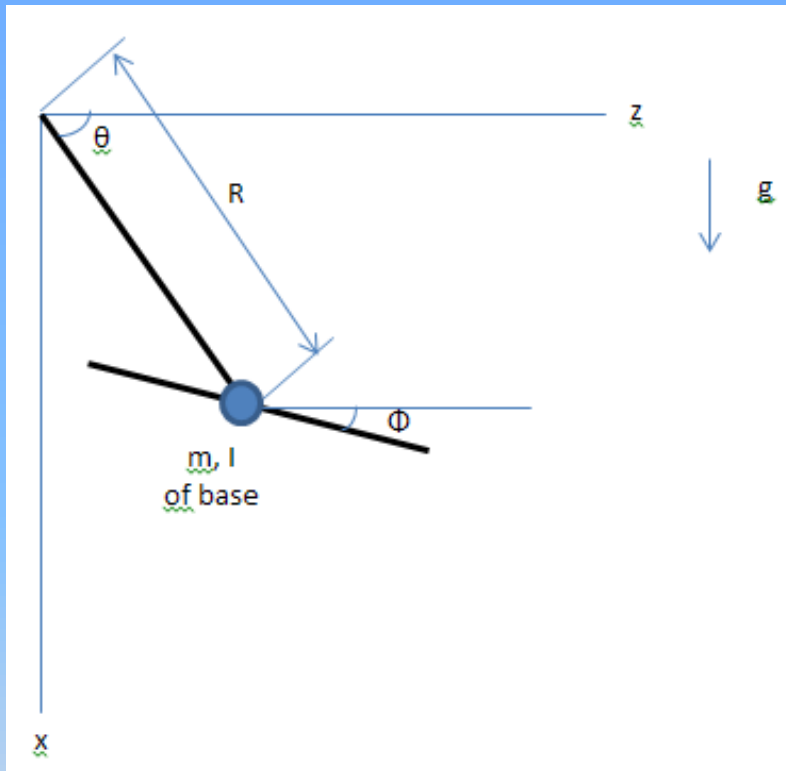

Model 1

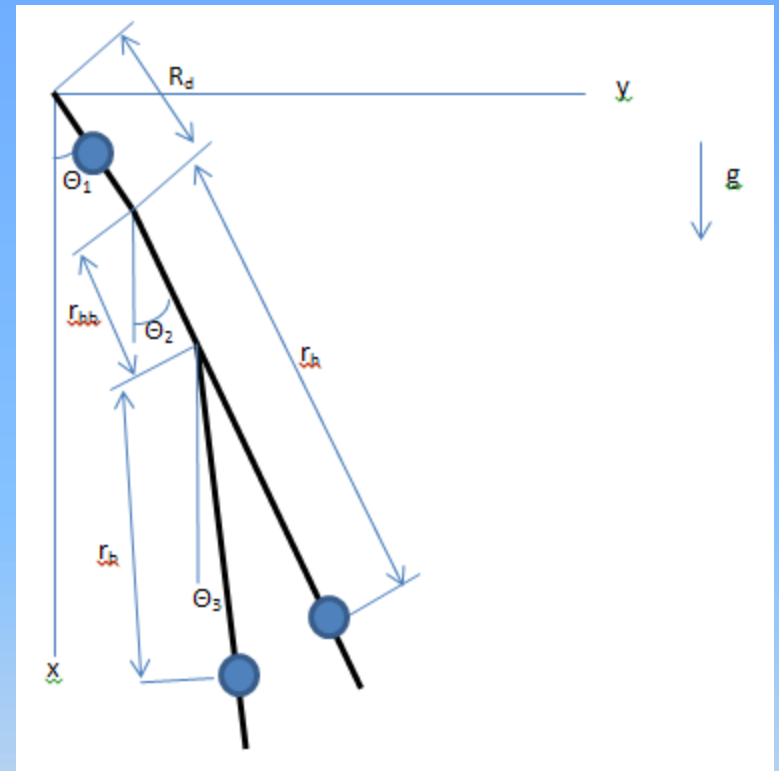

Model 2

# System Modeling

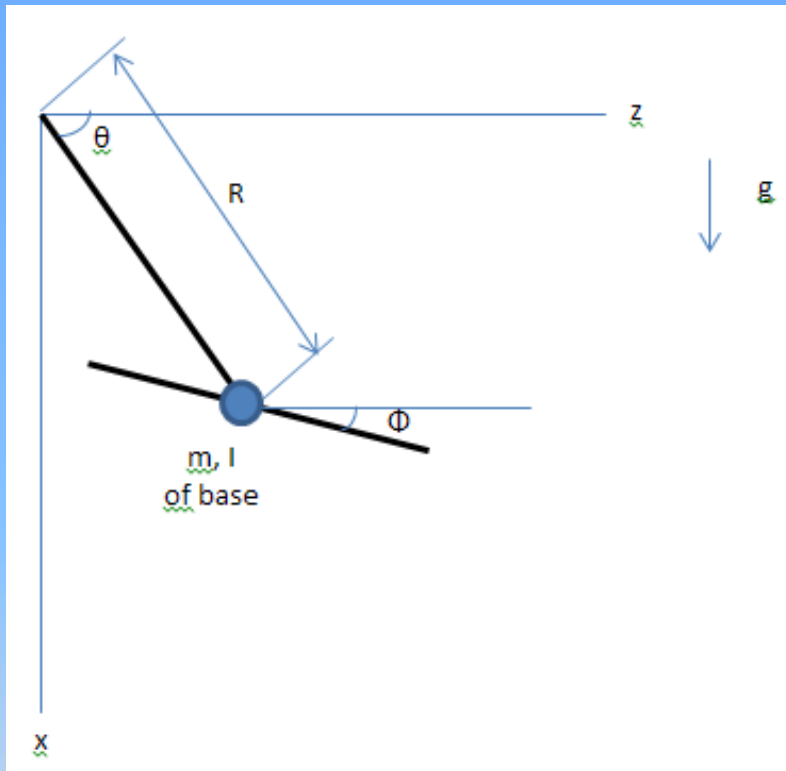

Model 1

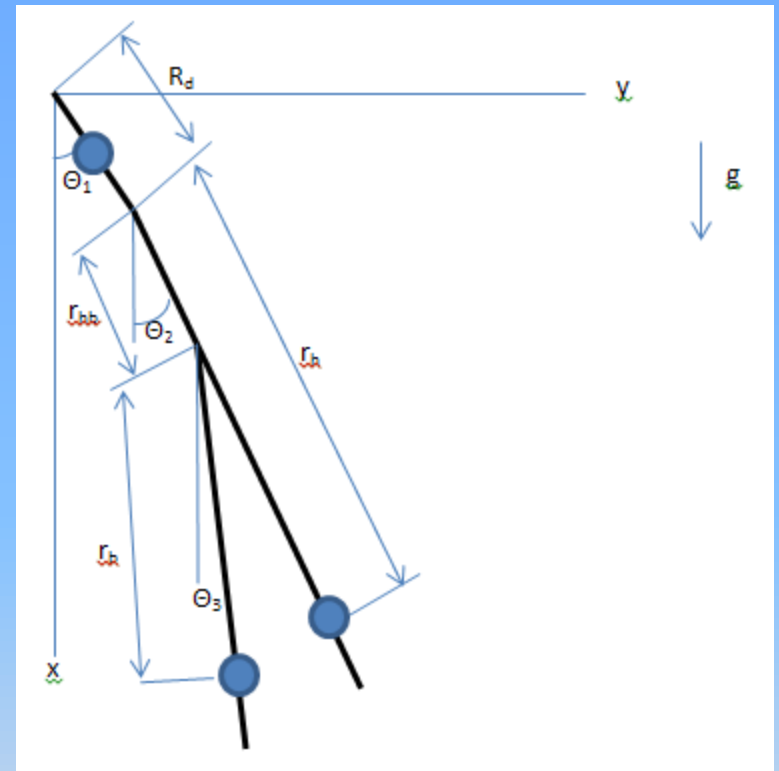

Model 2



# System Modeling

Test 1: 15 degree initial displacement

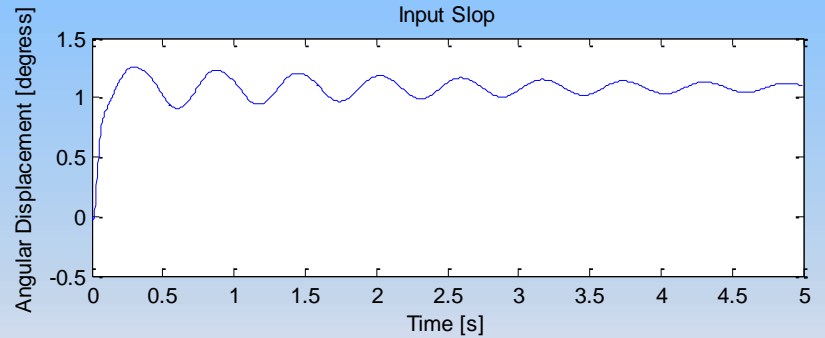
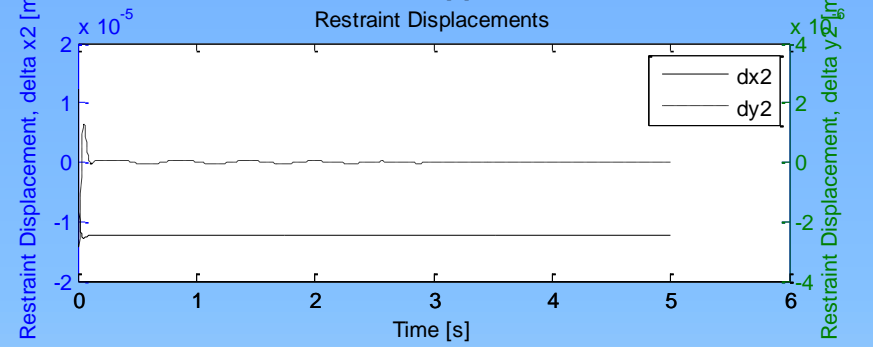
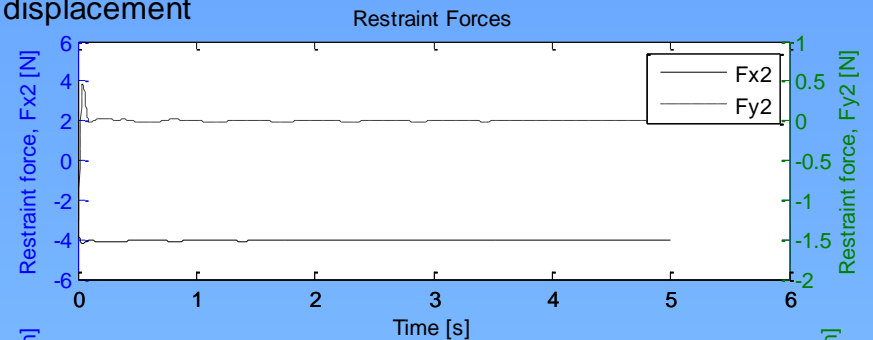
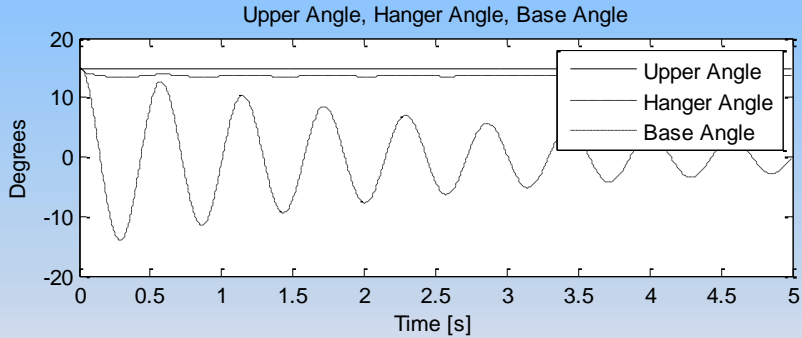
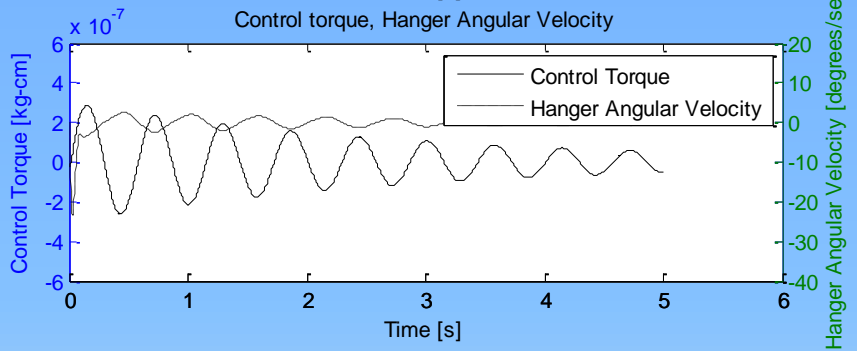
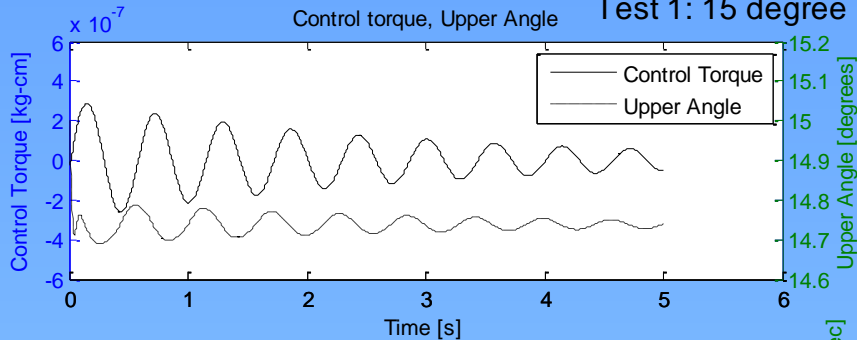

# System Modeling

## Test 2: PD Torque Control

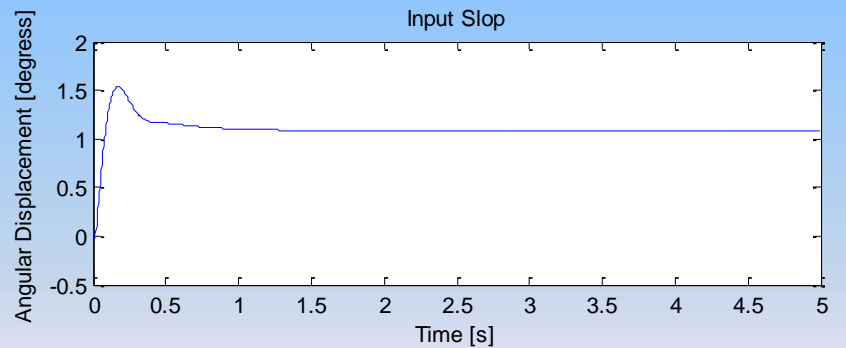
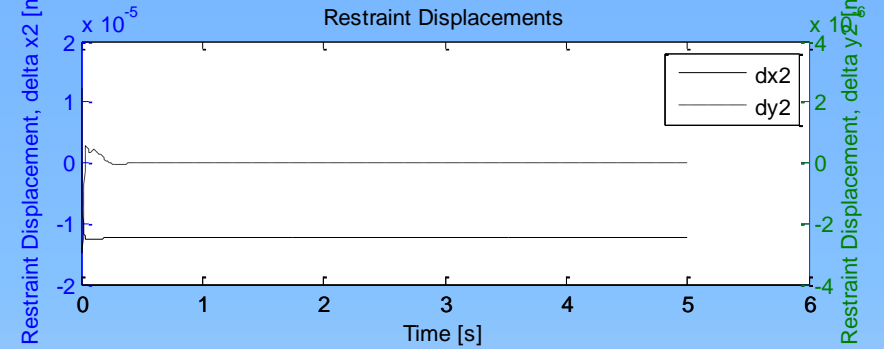
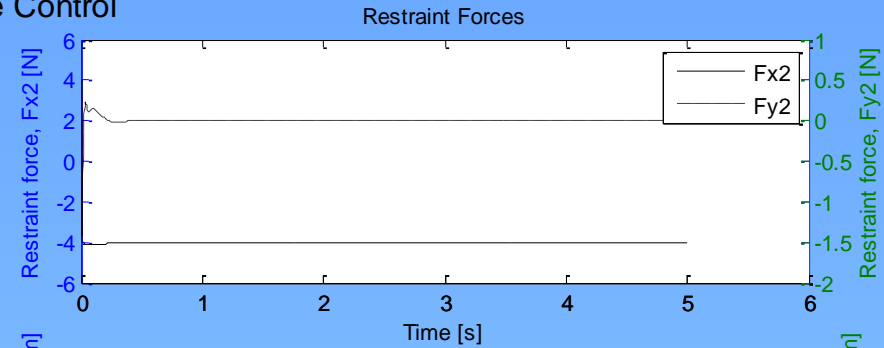
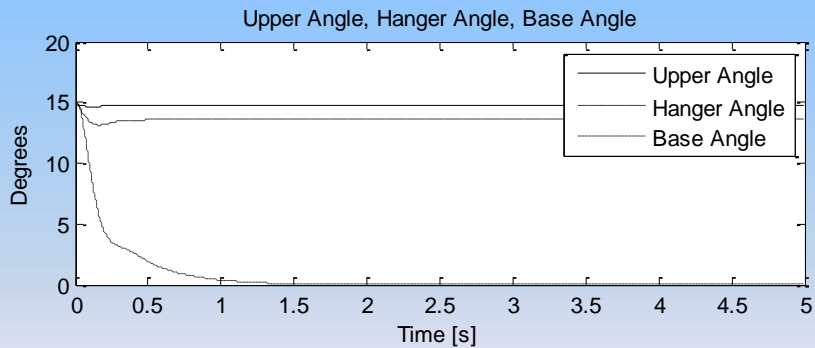
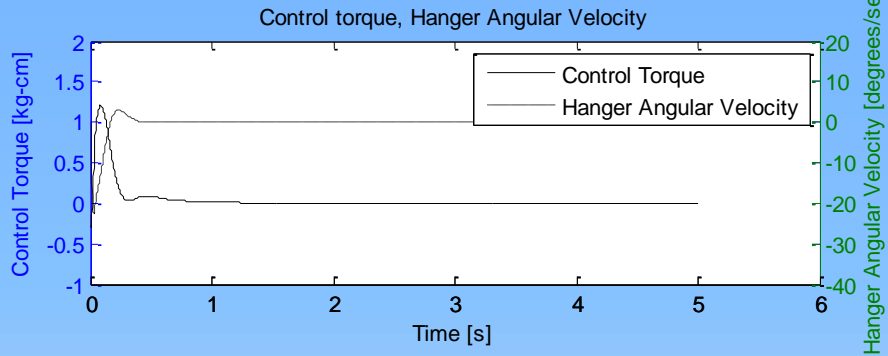
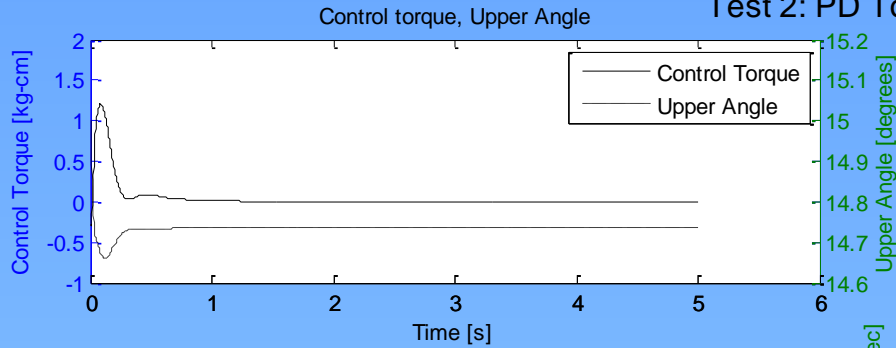

# System Modeling

## Test 3: PD Torque Control

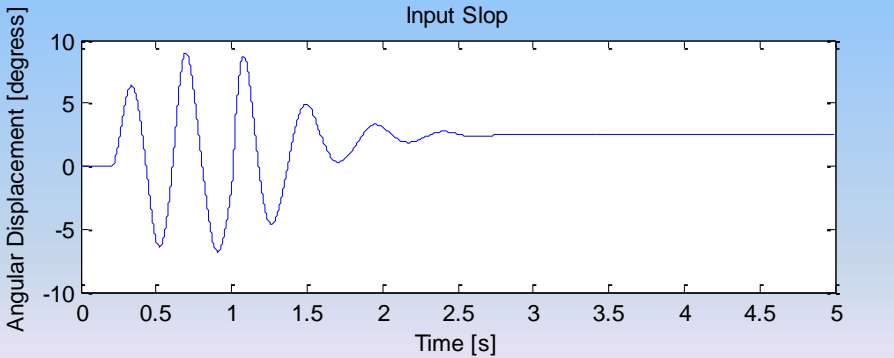
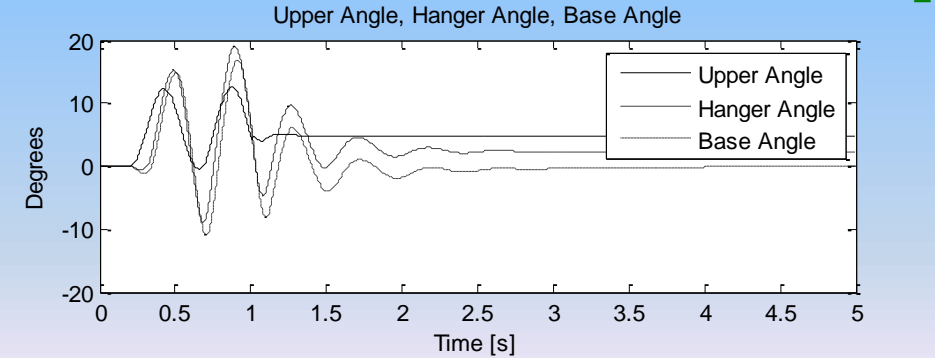
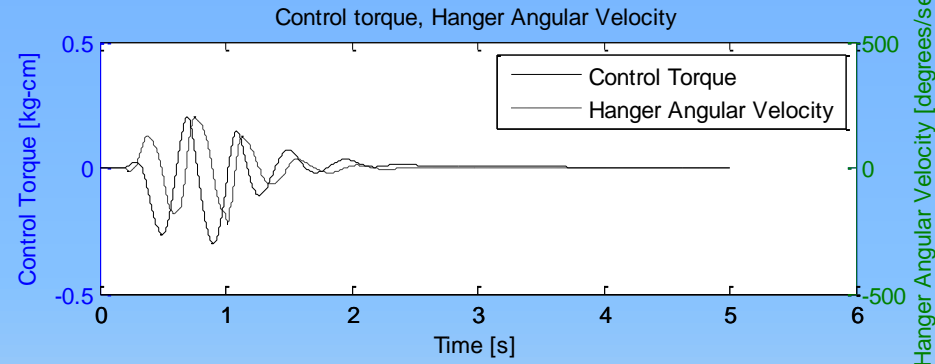
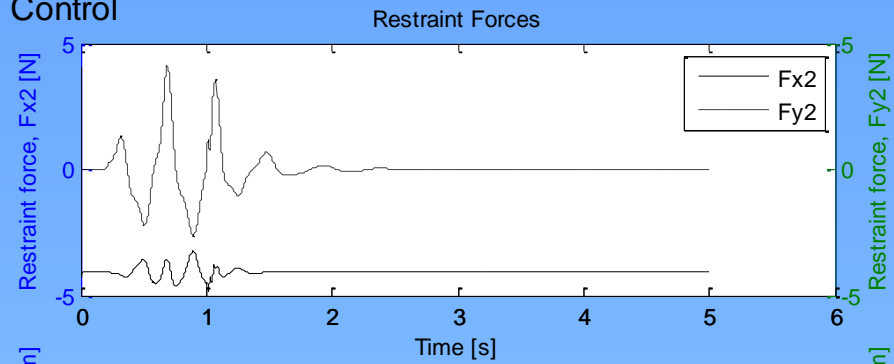
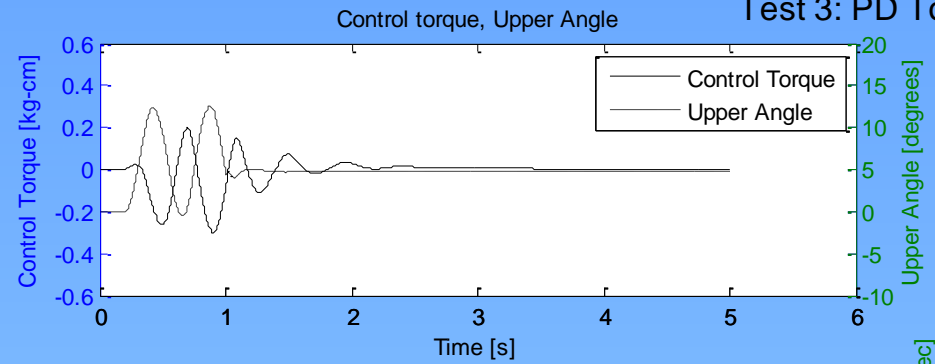

# System Modeling

## Test 4: Stiffer bushings

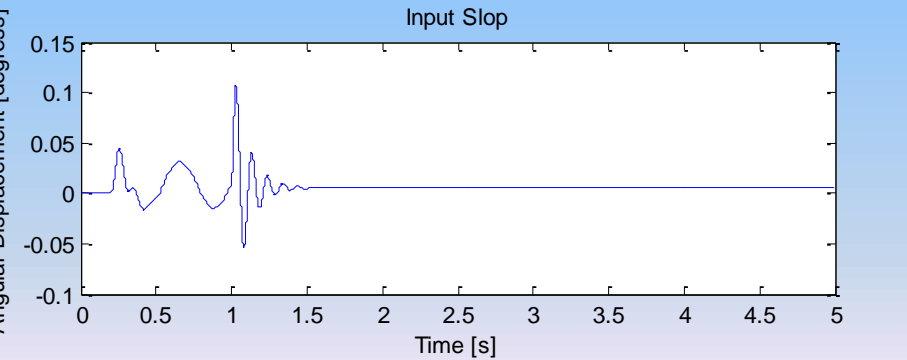
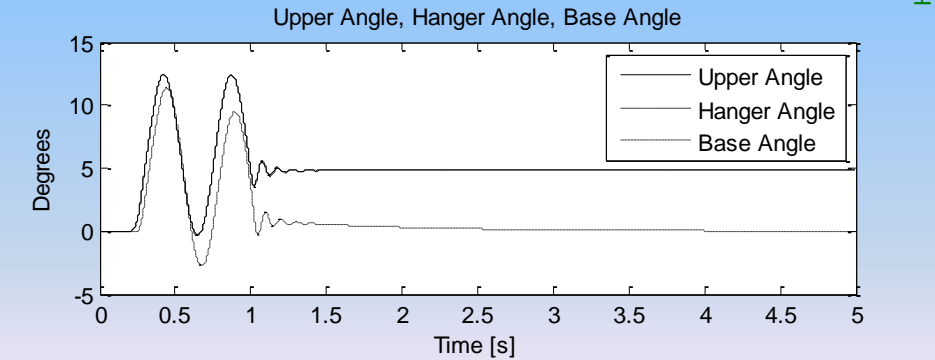
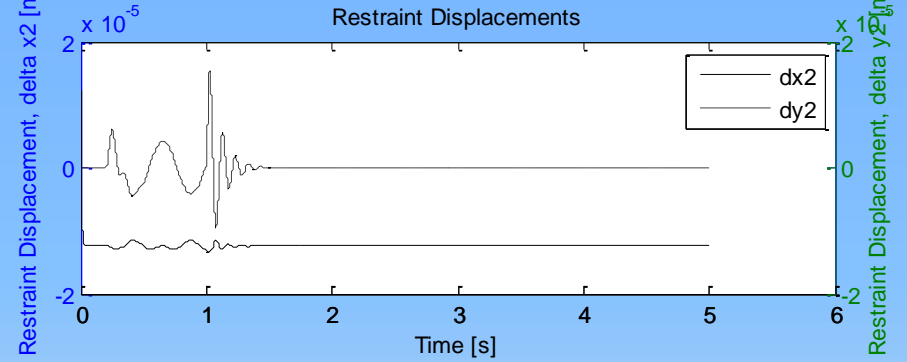
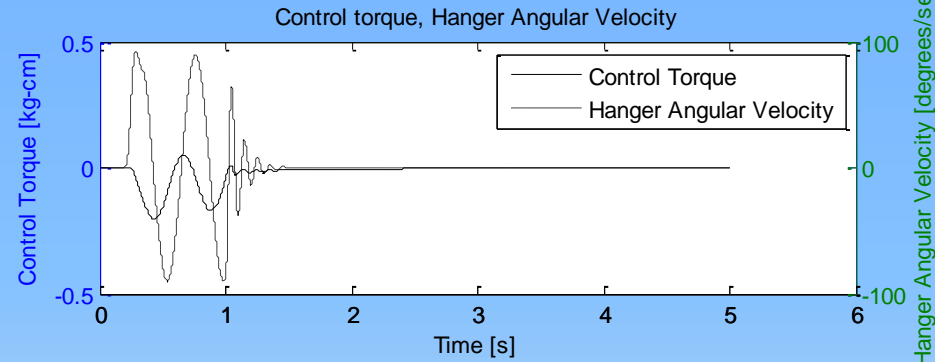
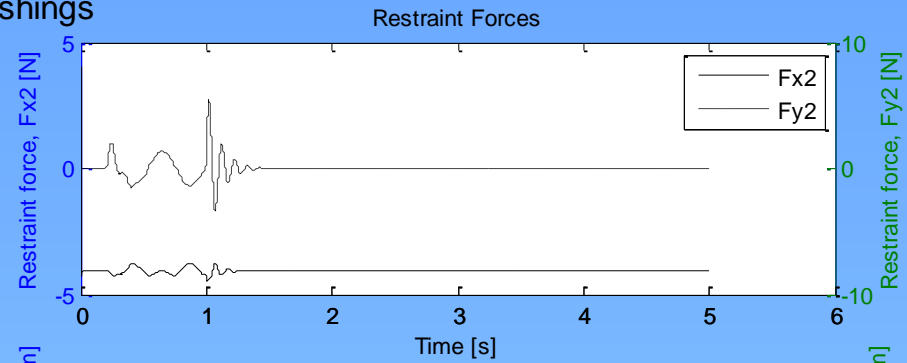
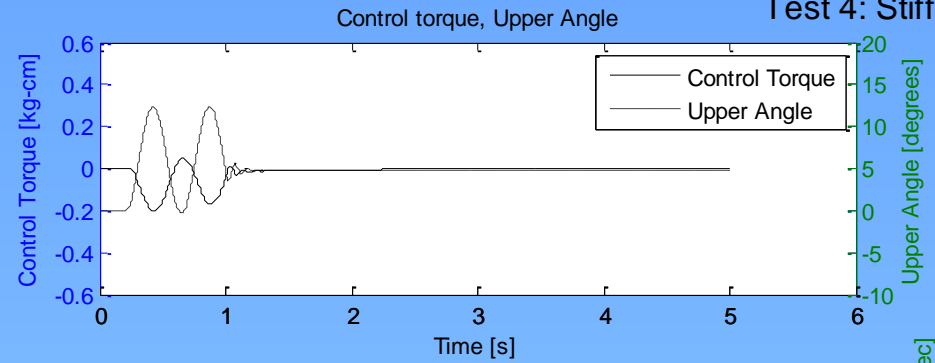

# CAD - Kevin



# Front View

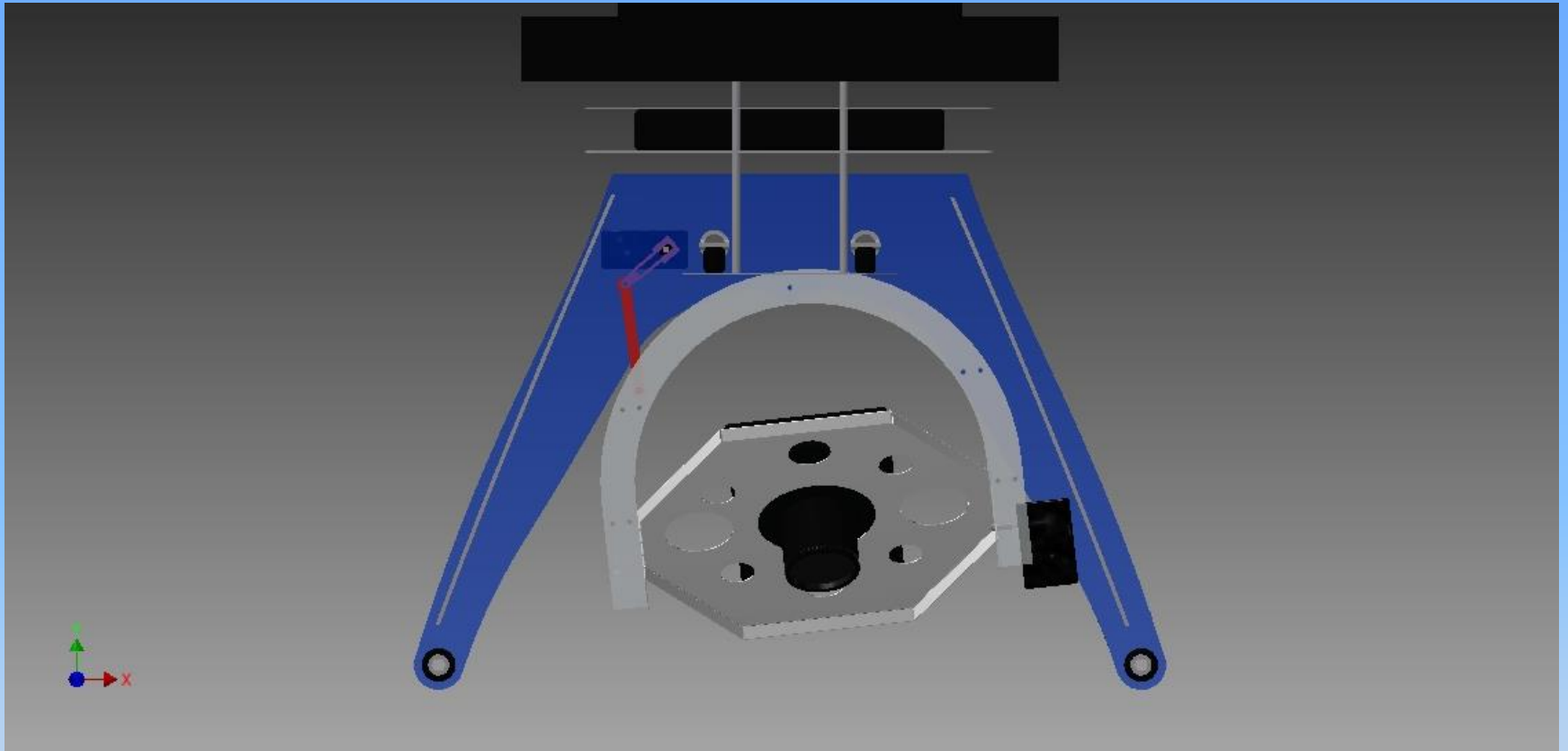



# Side View

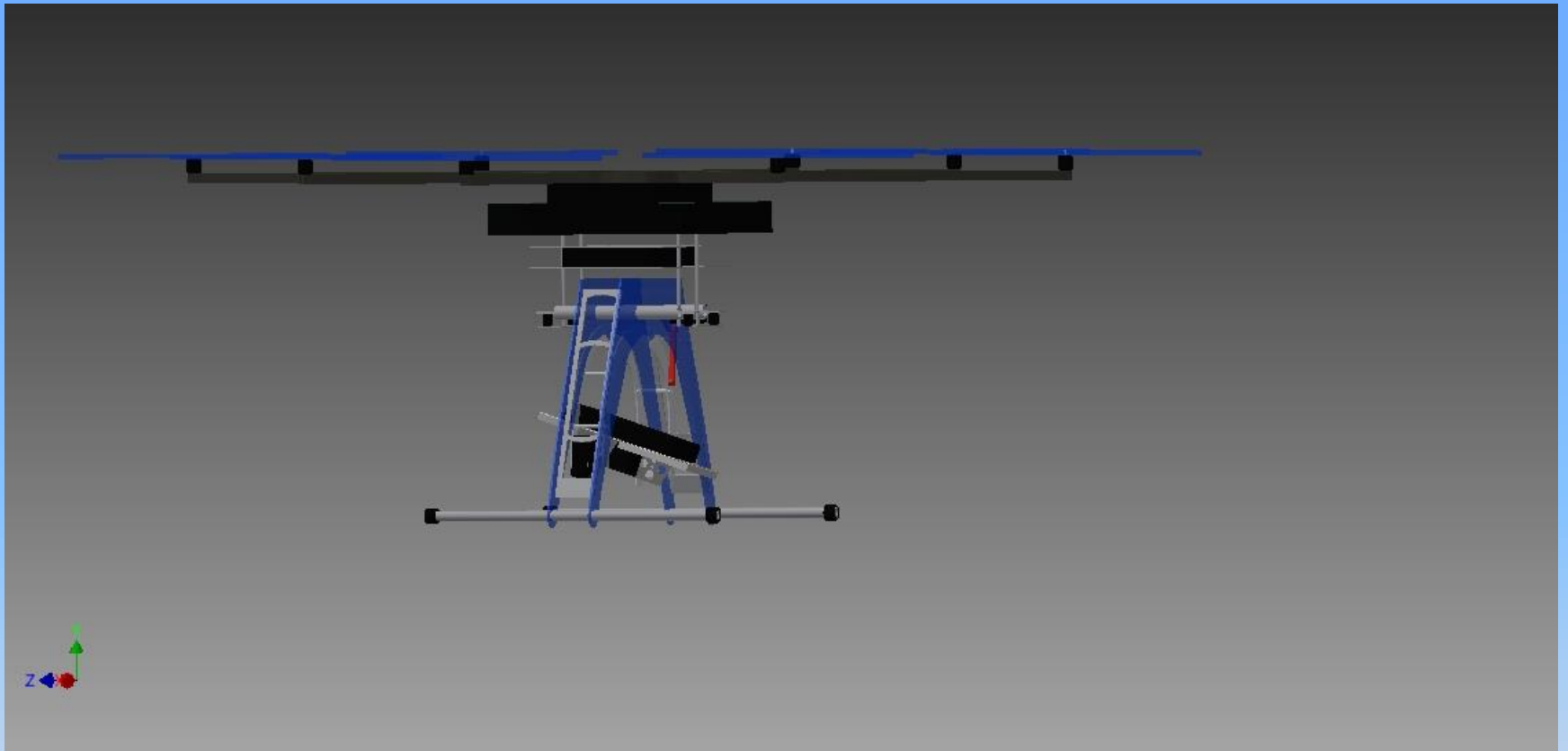

# CAD Animation

- [pitch.wmv](#)
- [roll9.wmv](#)

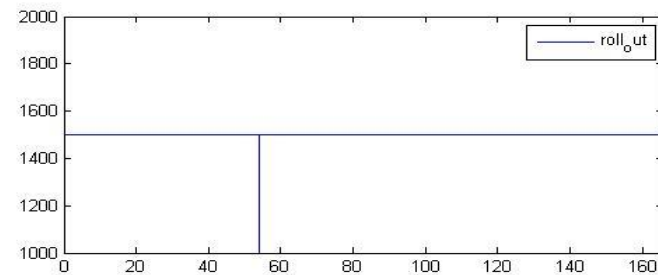
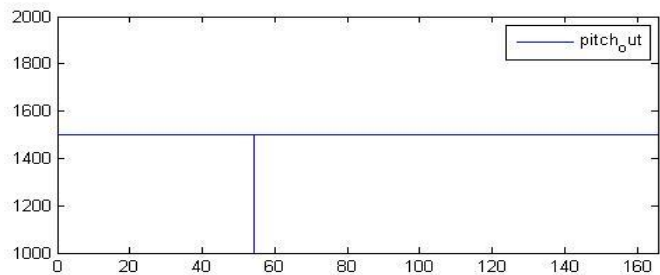
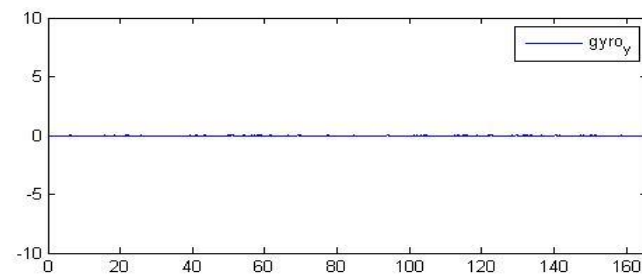
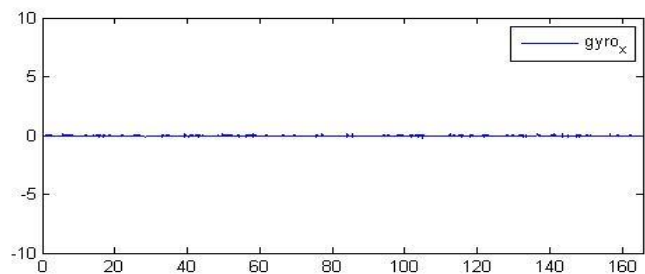
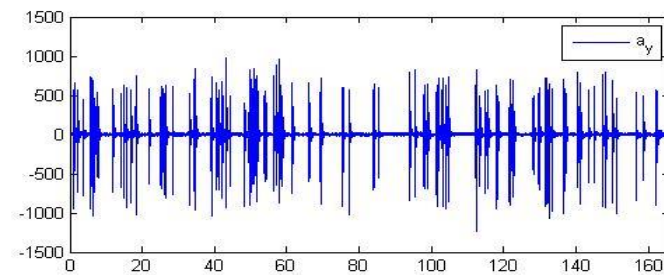
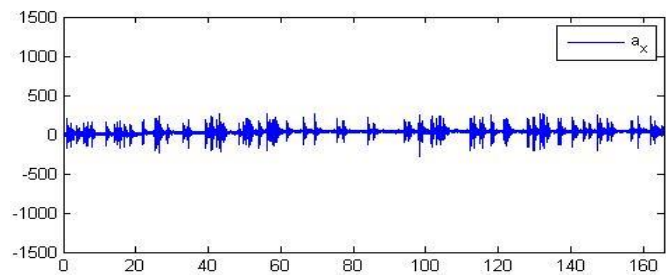

# Current Progress / Status

- Better servos
- Tightening/eliminating bushings for tighter response

# To be done...

- Play around with control code
- Apply model results to system
- Quantify progress through imaging target

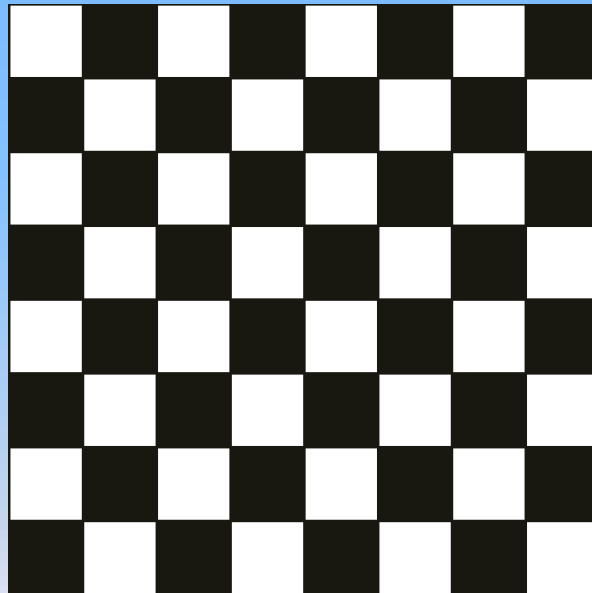



© GregVaughn.com

Questions?